

Installation and Instruction Manual

HYTRONIK®

HIGH BAY DUAL SENSE SENSOR

HIM31

1. Technical Specifications

Product type	Tri-level control dual sense sensor
Operating voltage	220-240VAC 50/60Hz
Rated load	800VA(Capacitive) 1000W(Resistive)
Power consumption	< 1W
Detection angle	360°
Detection area (Max.)*	Max installation height: 15m (forklift)/12m (human) Max detection range: HF: Ø = 24m (forklift)/14m (human) PIR: Ø = 24m (forklift)/20m (human)
Detection range	10% / 50% / 75% / 100%
Hold time	2s / 30s / 1min / 5min / 10min / 15min / 20min / 30min
Stand-by time	0s / 10s / 1min / 5min / 10min / 30min / 1h / +∞
Stand-by dimming level	10% / 20% / 30% / 50%
Daylight threshold	2 – 500Lux, Disable
Warming up time	30s
Operating temperature	-20°C – +50°C
IP rating	IP65
Sensor mode	HF, PIR, HF+PIR, HF / PIR

2. Rotary Switch Settings

A rotary switch is built inside the sensor for scene selection / fast programming. Total of 16 channels available:



Rotary switch preset (Please see the location in 2. Installation)

Channel	Detection range	Hold time	Stand-by time	Stand-by dimming level	Daylight threshold
0	100%	5s	10s	10%	Disable
1	100%	1min	5min	10%	2Lux
2	100%	5min	10min	10%	10Lux
3	100%	5min	30min	10%	30Lux
4	100%	5min	0s	Disable	10Lux
5	100%	5min	+∞	10%	30Lux
6	100%	5min	+∞	30%	Disable
7	100%	10min	10min	10%	2Lux
8	100%	10min	30min	10%	10Lux
9	100%	10min	+∞	10%	30Lux
A	100%	10min	+∞	30%	Disable
B	75%	10min	+∞	10%	30Lux
C	50%	10min	+∞	10%	10Lux
D	100%	30min	+∞	10%	50Lux
E	100%	30min	+∞	30%	Disable
F	100%	5s	10s	10%	2Lux

Note: settings can also be changed by remote control HRC-11. The last action controls.

3. Functions

3.1 Tri-level Control (Corridor Function)

Hytronik builds this function inside the motion sensor to achieve tri-level control, for some areas it requires a light change notice before switch-off. It offers 3 levels of light: 100%-->dimmed light-->off; and 2 periods of selectable waiting time: motion hold-time and stand-by period; Selectable daylight threshold and freedom of detection area.

3.2 Lux Off Function

The built-in daylight sensor can read ambient natural light and switch off the fixture automatically whenever artificial light is unnecessary (natural light lux level exceeds daylight threshold). Note: if the stand-by time is preset at "+∞", the fixture never switches off even when natural light is sufficient.

3.3 Load Indication

The light will flash ONCE rapidly after receiving the command from the remote controller. Note: There is no load indication (the light will not flash) when button ON/OFF, POWER 100% or POWER 80% is pressed.

WWW.HYTRONIK.COM

4. Installation

⚠ Warnings:

- Installation of the sensor involves connecting it to the mains supply. This work must be carried out by a specialist in accordance with electrotechnical regulations.
- Disconnect power supply before installing.

A. Ceiling mount

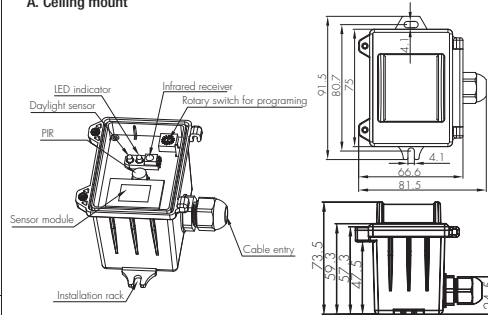

B. Screw to the Luminaire by conduit

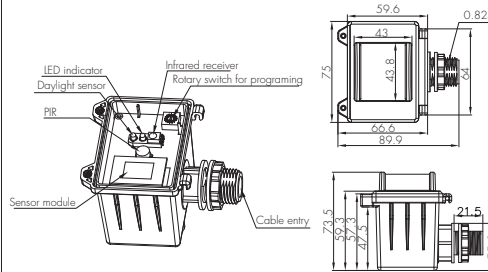

C. Attach to the shade by clamp

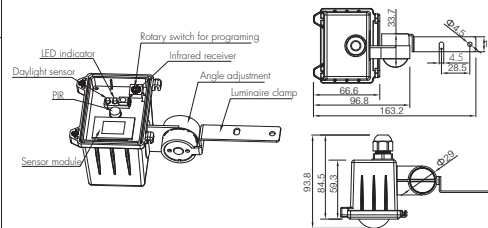

Note: We recommend the mounting distance between sensor to sensor should be more than 2m to prevent sensors from false-triggering.

HYTRONIK®

HIM31-20230628-A1

5. Wiring Diagram

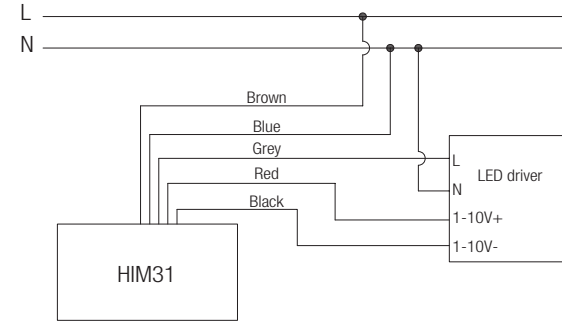

— This product should be installed by a qualified electrician.

6. Three Options for PIR Lens and Detection Patterns (End user can choose the suitable lens in real application for various requirements)

* For single person walking across, the detection range is reduced by 1/3.

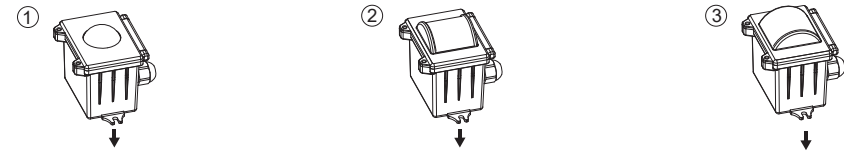

Detection pattern for forklift

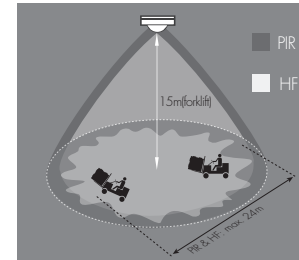

PIR detection: Ø = 24m (max.)

HF detection: Ø = 24m (max.)

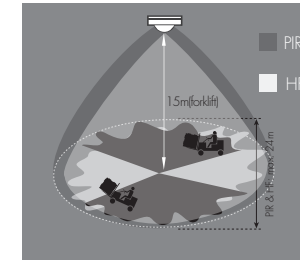

PIR detection: Ø = 24m (max.)

HF detection: Ø = 24m (max.)

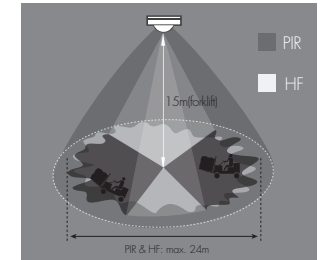

PIR detection: Ø = 24m (max.)

HF detection: Ø = 24m (max.)

Detection pattern for human

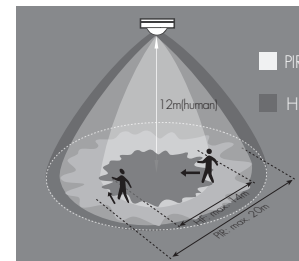

HF detection: Ø = 14m (max.)

PIR detection: Ø = 20m (max.)

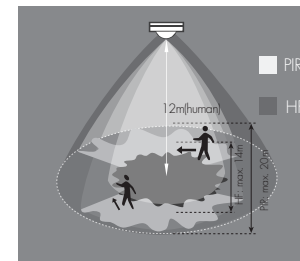

HF detection: Ø = 14m (max.)

PIR detection: Ø = 20m (max.)

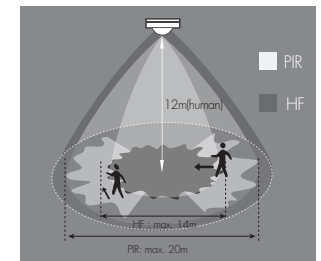

HF detection: Ø = 14m (max.)

PIR detection: Ø = 20m (max.)

WWW.HYTRONIK.COM

HYTRONIK®

HIM31-20230628-A1

7. Descriptions of the Button Functions (remote control HRC-11)

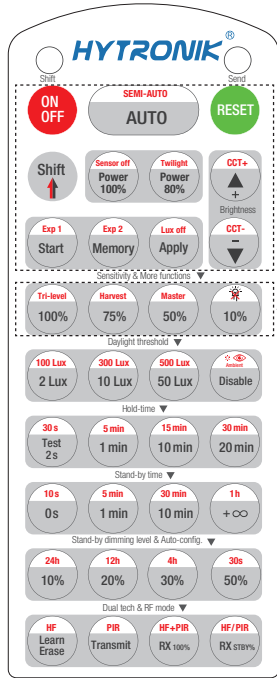

HRC-11

ON OFF	Press button "ON/OFF" to select permanent ON or permanent OFF mode. * Press button "AUTO"/"RESET" to exit this mode.
RESET	Press button "RESET", perform DIP Switch/Rotary Switch settings. *The default settings are: Detection range 100%; Holdtime 5min; Stand-by time +∞; Stand-by dimming level 30%; Daylight threshold disable; HF/PIR detection mode.
Shift	Press button "Shift", the LED on the top left corner is on to indicate mode selection. All values / settings in RED are valid for 20 seconds.
AUTO	Press button "AUTO" to initiate automatic mode. The sensor starts working and all settings remain as before the light is switched ON/OFF;
SEMI-AUTO	1. Press button "Shift", the red LED on. 2. Press button "SEMI-AUTO" to initiate Semi-auto mode. The sensor is only activated with the manual press of push switch. To exit this mode, simply press button "AUTO". <i>For Sensor LED indicator references: Remains on 2s, initiate "Semi-auto" mode from "Auto" mode.</i>
Power 100% 80%	Press buttons in zone "Power out" to select the light output at 80% (at initial 10,000 hours) or 100%.
Sensor off Twilight	This key is not applicable on this product.
CCT+ CCT-	Press these two buttons to adjust the light output brightness and set a new target lux level. The daylight sensor can measure ambient daylight level and ignore the LED light, so as to calculate how much artificial light is needed to maintain the target lux level.
Start Memory Apply	1. Press button "Start" to program. 2. Select the buttons in "Detection range", "Daylight threshold", "Hold-time", "Stand-by time", "Stand-by dimming level" to set all parameters. 3. Press button "Memory" to save all the settings programmed in the remote control. 4. Press button "Apply" to set the settings to each sensor unit(s). <i>For example, to set detection range 100%, daylight threshold Disable, hold-time 5min, stand-by time +∞, stand-by dimming level 30%, the steps should be: Press button "Start", button "100%", "Disable", "Shift", "5min", "Shift", "+∞", "30%", "Memory". By pointing to the sensor unit(s) and pressing "Apply", all settings are passed on the sensor(s).</i>
Lux off	This key is not applicable on this product.
Exp 1 Exp 2	"Exp" refer to Expansion, these two buttons are reserved functions and pending future development.
Sensitivity & More functions	
100% 75% 50% 10%	In AUTO /SEMI-AUTO modes, press buttons in zone "Detection range" to set detection range at 100%/75%/50%/10%.
Tri-level Harvest	This key is not applicable on this product.
Master	This key is not applicable on this product.

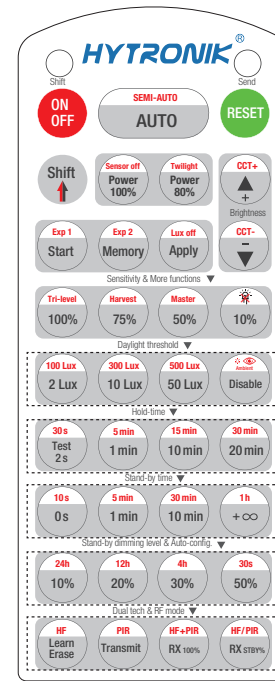

HRC-11

Daylight threshold	
2 Lux 100 Lux 10 Lux 300 Lux 50 Lux 500 Lux Disable	Press buttons in zone "Daylight threshold" to set daylight sensor at 2Lux/ 10Lux / 50Lux / 100Lux / 300Lux/500Lux / Disable. <i>Note: To set daylight sensor at 100Lux / 300Lux/500Lux , press "Shift" button first.</i>
Ambient	1. Press button "Shift", the red LED on. 2. Press button "Ambient", the surrounding lux level is sampled and set as daylight threshold / target Lux level.
Hold-time mode	
Test 2s 1min 5min 10min 15min 20min 30min	In AUTO /SEMI-AUTO modes, press buttons in zone "hold-time" to set the hold-time at 2s / 30s / 1min / 5min / 10min / 15min / 20min / 30min. <i>Note: 1. To set hold-time at 30s / 5min / 15min / 30min, press "Shift" button first. 2. 2s is for testing purpose only, stand-by period and daylight sensor settings are disabled in this mode.</i> * To exit from Test mode, press button "RESET" or any button in "Hold-time".
Stand-by time mode	
0s 10s 1min 5min 10min 30min +∞ 1h	Press buttons in zone "stand-by time" to set the stand-by period at 0s / 10s / 1min / 5min / 10min / 30min / 1h / +∞. <i>Note: 1. To set stand-by-time at 10s/ 5min / 30min / 1h, press "Shift" button first. 2. "0s" means on/off control; 3. "+∞" means bi-level control, the fixture is 100% on when there is motion detected, and remains at the stand-by dimming level when no presence after motion hold-time. Only when the stand-by time is set in "+∞" and the ambient lux level is below the target lux level, the lux will auto-on.</i>
Stand-by dimming level & Auto-config.	
10% 20% 30% 50%	Press the button in zone "stand-by dimming level" to set the stand-by dimming level at 10% / 20% / 30% / 50%.
24h 12h 4h 30s	This key is not applicable on this product.
Dual tech & RF mode	
Learn Erase	Short press "learn/erase" button to activate pairing mode, then press "transmit" on a primary mode and all the receiver modules will beep 3 times in 1s to indicate the success of pairing. Long press the "learn/erase" button for 3s will erase all the commands received previously.
Transmit	Press button RX 100%, the light on receiver unit is 100% upon receiving RF on signal; Press button "RX STBY%", the light(s) goes to pre-set stand-by dimming level directly.
HF PIR HF+PIR HF/PIR	1. Press button "Shift", the red LED on. 2. Choose one of the four detection mode "HF only", "PIR only", "HF & PIR" or "HF/PIR".

8. Trouble Shooting

MALFUNCTION CAUSE REMEDY	CAUSE	REMEDY
The fixture does not light up	Incorrect daylight threshold setting	Adjust daylight threshold setting
	Faulty fixture	Replace fixture
	No power supply	Check power to sensor
The fixture is always on	Detection zone not targeted	Check detection area setting
	Continuous movement in the detection zone	Check detection area setting
The fixture is on when it should not	Sudden change in temperature due to weather (wind, rain, snow) or air expelled from fans, open windows	Adjust zone, change installation site

9. Additional Information / Documents

- Regarding precautions for microwave sensor installation and operation, please kindly refer to www.hytronik.com/download ->knowledge ->Microwave Sensors - Precautions for Product Installation and Operation
- Regarding precautions for PIR sensor installation and operation, please kindly refer to www.hytronik.com/download ->knowledge ->PIR Sensors - Precautions for Product Installation and Operation
- Regarding Hytronik standard guarantee policy, please refer to www.hytronik.com/download ->knowledge ->Hytronik Standard Guarantee Policy